

Multi-functional Precision Balances

GX/GF

Series



GX-400
(with optional glass breeze break)



GX-600
(with standard breeze break)



The World's Most User-Friendly Balances...

Our Super Hybrid Sensor (SHS)*, which combines the best of magnetic force restoration and single point parallelogram load sensing technologies, offers you the ultimate in response speed – Just 1 Second! *Patent Approved

Internal Calibration

The GX internal calibration with an internal mass saves time and money. External calibration requires a great deal of skill and time as well as an expensive external mass. With our internal calibration with internal mass, the balance can be calibrated very quickly.

- Automatic self calibration – Self-calibrates automatically when the balance detects ambient temperature changes
- One touch automatic calibration – Allows you to calibrate the balance on demand with just the push of a button

Quick USB Interface (GX-02)

Easy-to-use optional USB interface, with no driver or software installation necessary, for transfer of weighing data to a computer (Unidirectional communication from a balance to a PC only. Please use the standard RS-232C interface for sending commands from a PC to the balance.)



GX

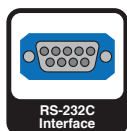



GF

VFD – Vacuum Fluorescent Display

Large VFD is clearly visible even in a poorly-lit workplace.



GLP/GMP/GCP/ISO Compliant

In accordance with GLP and LIMS regulations, the balance ID number and calibration data can be printed out using A&D's AD-8121B or a PC.

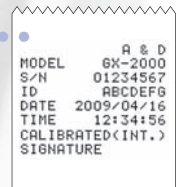

ACAI – Automatic Counting Accuracy Improvement

This counting function recalculates the average unit weight each time a sample is added to eliminate errors caused by variations in unit weight.



Quick Reference Card

A convenient operating guide is located at the bottom of the balance.

Density Measurement Function

An optional Density Determination Kit (GX-13) is available.



GX-13

Automatic Response Speed Adjustment (GX only)

The response rate is set automatically at either FAST, MID, or SLOW depending on the environmental conditions. (Manual selection is available for the GF Series.)



(GX)

(GF)

Specifications

	GX-200	GX-400	GX-600	GX-800	GX-1000		GX-2000	GX-4000	GX-6100	GX-6000	GX-8000		
	GF-200	GF-300	GF-400	GF-600	GF-800	GF-1000	GF-1200	GF-2000	GF-3000	GF-4000	GF-6100	GF-8000	
Weighing capacity	210g	310g	410g	610g	810g	1100g	1210g	2100g	3100g	4100g	6100g	8100g	
Minimum weighing value	0.001g						0.01g				0.1g		
Repeatability (Standard Deviation)	0.001g						0.01g				0.1g		
Linearity	±0.002g			±0.003g			±0.02g				±0.03g		±0.1g
Stabilization time (typical at FAST)	Approx. 1second				Approx. 1.5 seconds		Approx. 1 second				Approx. 1.5seconds	Approx. 1 second	
Sensitivity drift (10°C to 30°C/50°F-80°F)	±2ppm/°C (When automatic self calibration is not used)											±5ppm/°C (auto-self calibration OFF)	
Operating temperature	5°C to 40°C (41°F to 104°F), 85%RH or less (No condensation)												
Sensing method	Super Hybrid Sensor (SHS) *SHS: Patent approved												
Display type	Vacuum Fluorescent Display (VFD)												
Display refresh rate	5 times/second or 10 times/second												
Counting mode	Minimum unit mass	0.001g					0.01g				0.1g		
	Number of samples	10, 25, 50 or 100 pieces											
Percent mode	Minimum 100% reference mass	0.100g					1.00g				10.0g		
	Minimum 100% display	0.01%, 0.1%, 1% (Depends on reference mass stored)											
Standard serial I/F	RS-232C Interface with Windows Communication Tools (WinCT: included as CD-ROM)												
Weighing pan	128 x 128mm (5.04 x 5.04 inch)						165 x 165mm (6.50 x 6.50 inch)						
Calibration	Motor-driven Internal Calibration (GX only)												
External dimensions	210(W) x 317(D) x 86(H)mm (8.27 x 12.48 x 3.39 inch)												
AC adapter	Confirm that the adapter type is correct for the local voltage and power receptacle												
Power consumption	Approx. 11VA (supplied by AC adapter)												
Net weight	Approx. 4.6kg(GX)/3.8kg(GF)						Approx. 5.1kg(GX)/4.3kg(GF)						

Notes: The internal mass is equal to (approximately) 500 grams.
EC Type Approval Confirmed (Approval No. UK2560)
Standard Breeze break included for 1mg minimum weighing value models

Options

- GX-02¹⁾ Quick USB Interface with cable
- GX-04^{1,2)} Comparator Output with a Buzzer/ RS-232C/Current Loop Output
- GX-06^{1,2)} Analog Output/Current Loop Output
- GX-10 Glass Breeze Break for 128 x 128mm weighing pan size models
- GX-11 Glass Breeze Break for 165 x 165mm weighing pan size models
- GX-12 Animal Weighing Pan (not available for GX-200 and GF-200)
- GX-13 Density Determination Kit for 128 x 128mm weighing pan size models

1) GX-02, GX-04 GX-06 and standard RS-232C cannot be used at the same time.
2) Factory installed option

Accessories

- AD-1682 Rechargeable battery unit (Maximum operating time: 8 hours)
- AD-1683 Static eliminator
- AD-1684 Electrostatic fieldmeter
- AD-1688 Weighing data logger
- AD-1689 Tweezers for calibration weight
- AD-8121B Dot matrix compact printer
- AD-8526 Serial/Ethernet converter
- AD-8527 Quick USB adapter
- AD-8920A Remote display
- AD-8922A Remote controller
- AX-USB-25P Serial/USB converter
- AX-KO1710-200 RS-232C cable (25P-9P)
- AX-SW128 Foot switch
- AX-073003691-S Dust cover for 128 x 128mm weighing pan size models
- AX-073003692-S Dust cover for 165 x 165mm weighing pan size models

Physical Dimensions (mm)

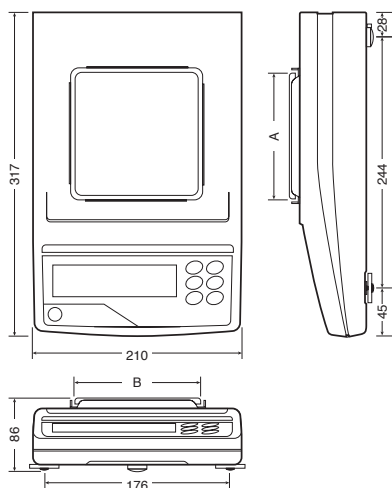

Pan size (mm)

Model	A	B
GX-200/400/600/800/1000	128	128
GF-200/300/400/600/800/1000		
GX-2000/4000/6100/6000/8000	165	165
GF-1200/2000/3000/4000/6100/6000/8000		

Dimensions With Optional Glass Breeze Break (mm)

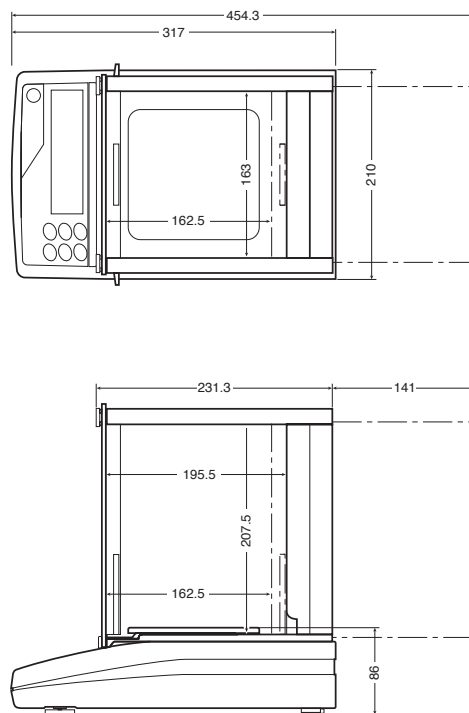

Specifications subject to change for improvement without notice.



WolfLabs

Pricing on any accessories shown can be found by keying the part number into the search box on our website.

The specifications listed in this brochure are subject to change by the manufacturer and therefore cannot be guaranteed to be correct. If there are aspects of the specification that must be guaranteed, please provide these to our sales team so that details can be confirmed.

www.wolflabs.co.uk

Tel : 01759 301142

Fax : 01759 301143

sales@wolflabs.co.uk

Please contact us if this literature doesn't answer all your questions.